

A16062 Series 160X160X62mm(6.30"X6.30"X2.44")

[View WebPage](#)
[View 3D Object](#)



HOUSING	Die-Cast Aluminum, Painted Black
IMPELLER	Injection Molded of Flame Retardant Petardant Polycarbonate, Black
BEARING	Ball
TERMINATION	Terminals or Lead Wire
DIELECTRIC STRENGTH	1,500VAC for 1 minute
INSULATION	Class B
INSULATION RESISTANCE	100,000 Ohms min. @500 VDC
OPERATING TEMPERATURE	-20 °C to + 80 °C
SAFETY	Thermally Protected (Auto Restart)
WEIGHT	1.4Kgs
ROHS COMPLIANCE	Yes

SPECIFICATION

MODEL NO.	RATED VOLTAGE (V)	FREQUENCY (Hz)	RATED CURRENT (A)	INPUT POWER (W)	SPEED RPM	MAX. AIR PRESSURE		AIR FLOW		NOISE dB(A) @1M
						InchH ₂ O	mmH ₂ O	m ³ /min	CFM	
A16062V1H	115	50/60	0.45/0.50	51/58	2900/3400	0.58/0.76	14.7/19.3	7.4/8.7	261/307	60/64
A16062V2H	230	50/60	0.23/0.25	51/57	2900/3400	0.58/0.76	14.7/19.3	7.4/8.6	261/305	60/64

DIMENSION

AIR PERFORMANCE

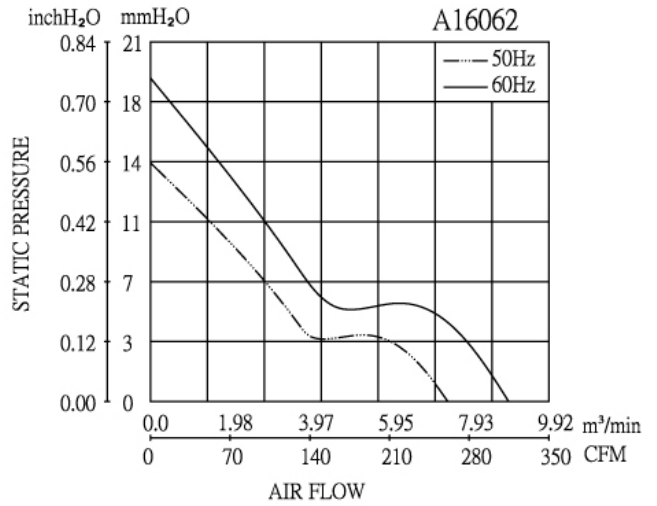
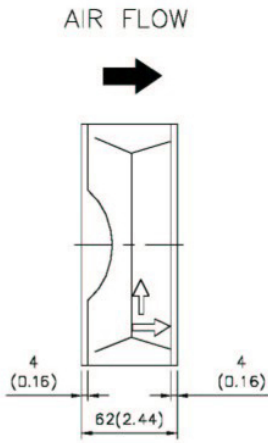
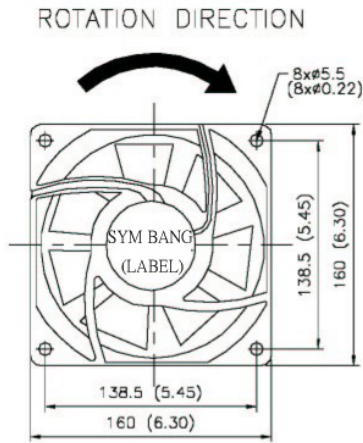

Mountion Panel Cutout
Outlet Side & Inlet Side

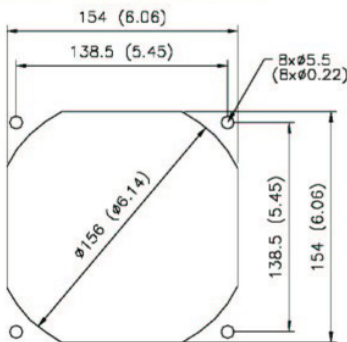

UNIT:mm (inch)